

DRAWINGS ATTACHED

- (21) Application No. 25451/70 (22) Filed 27 May 1970
- (31) Convention Application No. 9046 (32) Filed 13 June 1969 in
- (33) Switzerland (CH)
- (45) Complete Specification published 1 Nov. 1972
- (51) International Classification H02K 33/00
- (52) Index at acceptance H2A 1B2D 1B2J 1B2M 1B2N 24



(54) ELECTROMAGNETIC MICROMOTOR

(71) We, COMPAGNIE DES MONTRESS LONGINES, FRANCILLON S.A. of 2610 Saint-Imier, Switzerland and BERNARD GOLAY S.A. of 2 Croix-Rouge, 1000 Lausanne, Switzerland; both Swiss body corporates, do hereby declare the invention, for which we pray that a patent may be granted to us, and the method by which it is to be performed, to be particularly described in and by the following statement:—

The present invention relates to an electromagnetic micromotor.

Known motors of this type include pole pieces which are rather long with respect to the length of the permanent magnets. When short magnets having a very strong coercive field, such as platinum-cobalt magnets, are used, the losses due to the proximity of the pole pieces to one another, fixed respectively to each pole of the magnets, becomes very important, since the field in the air-gap is correspondingly reduced.

The invention aims at overcoming these drawbacks. The electromagnetic micromotor according to the invention includes at least one flat coil, stationary or movable, cooperating with at least one magnetic circuit, movable or stationary respectively, consisting of one pair of permanent magnets and two pairs of pole pieces, and is characterized in that the magnets have their magnetic axes parallel to the plane of the coil and are arranged in the close vicinity of said coil, the magnetic axes of the magnets being also parallel to each other and their magnetic fields being of opposite senses, the pole pieces serving to direct the magnetic flux through the coil being fixed respectively on the faces constituting the poles of the magnets and covering the latter without extending beyond them.

The accompanying drawings illustrate, by way of example, an embodiment of the invention.

Fig. 1 is a perspective view of said embodiment.

Fig. 2 is a cross-sectional view of the electromagnetic device.

[Price 25p]

Fig. 1 illustrates a portion of a frame the legs $1a$ and $1b$ of which present a certain elasticity. The main compliance of the micromotor consists of a flat torsion blade 2. The torsion blade 2 is embedded at its both ends in the legs $1a$ and $1b$ of the frame, and carries in the middle thereof a mass, which includes a rigid bar 3, extending on both sides of the torsion blade 2. At the ends of the bar 3 are fixed respectively a flat coil 4 and a counterweight (not shown) in such a manner that a static equilibrium is obtained about the axis of the torsion blade 2.

The coil 4 is located in a stationary magnetic circuit consisting of one pair of permanent magnets 5, 6 and two pairs of pole pieces 7, 8 and 9, 10. This electromagnetic device is driven by a very stable oscillator such as a quartz oscillator.

The magnets 5 and 6 have their magnetic axes parallel to the plane of the coil 4 and are arranged in the close vicinity of said coil, the magnetic axes of the magnets 5 and 6 being also parallel to each other and their fields being of opposite senses. More precisely, the magnet 5, having the shape of a parallelepiped, is magnetized vertically, its N pole being at the top and its S pole being at the bottom. As concerns the magnet 6, it has the same shape as the magnet 5 and is also magnetized vertically, but its N pole is at the bottom and its S pole is at the top.

The pole pieces 7, 8 and 9, 10 which direct the magnetic flux through the coil 4 are fixed on the faces constituting the poles of the magnets 5 and 6, and cover the latter without extending beyond them. Thus, the pole pieces 7 and 8 are respectively fixed on the faces constituting the N and S poles of the magnet 5, whereas the pole pieces 9 and 10 are respectively fixed on the faces constituting the S and N poles of the magnet 6. Each of the pole pieces 7 to 10 has the shape of a prism whose base is quasi-triangular, its thickness tapering from the coil 4, so as to avoid as much as possible the dispersion of the lines of force.

In the example described, the coil 4, car-

50
55
60
65
70
75
80
85
90

ried by the oscillating bar 3, is movable whereas the magnetic circuit is stationary. It would, however, be possible to have an inverse arrangement, in which the coil would be stationary and the magnetic circuit would be movable.

Other aspects of our invention are claimed in co-pending application No. 24450/70 (Serial No. 1,295,104).

10 WHAT WE CLAIM IS:—

1. A electromagnetic micromotor, including at least one flat coil, stationary or movable, cooperating with at least one magnetic circuit, movable or stationary, respectively, consisting of one pair of permanent magnets and two pairs of pole pieces, characterized in that the magnets have their magnetic axes parallel to the plane of the coil and are arranged in the

close vicinity of said coil, the magnetic axes of the magnets being also parallel to each other and their magnetic fields being of opposite senses, the pole pieces serving to direct the magnetic flux through the coil being fixed respectively on the faces constituting the poles of the magnets and covering the latter without extending beyond them.

2. A micromotor according to claim 1, wherein the magnets have the shape of parallelepipeds.

3. A micromotor according to claim 1, wherein each of the pole pieces has the shape of a quasi-triangular prism, its thickness tapering away from the coil.

4. A micromotor substantially as described with reference to the accompanying drawings.

POTTS, KERR & CO.

Printed for Her Majesty's Stationery Office by the Courier Press, Leamington Spa, 1972.
Published by the Patent Office, 25 Southampton Buildings, London, WC2A 1AY, from which copies may be obtained.

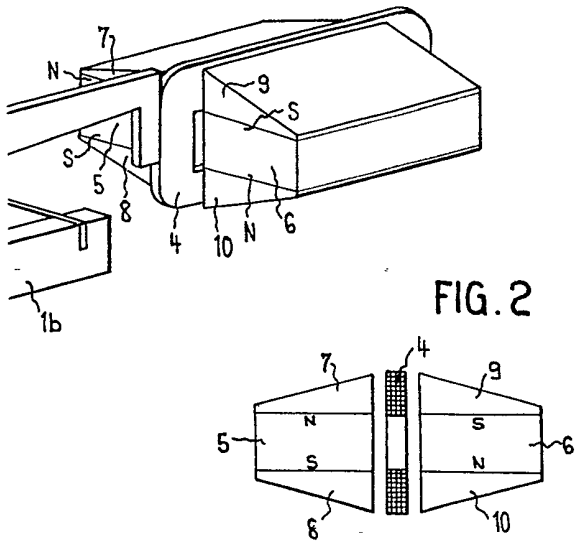
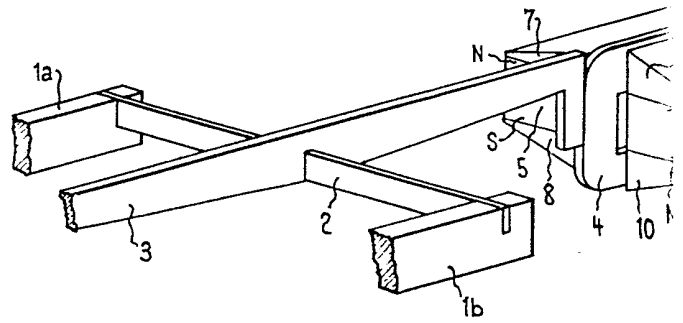

FIG. 1



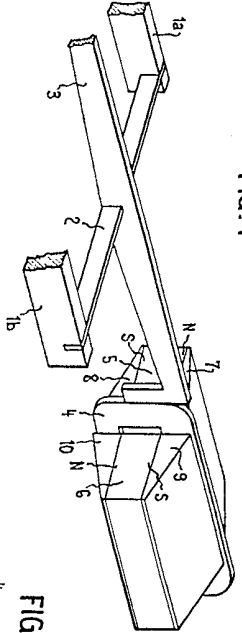

FIG. 1

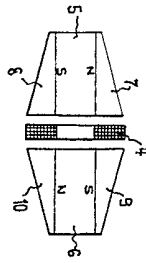

FIG. 2