

PATENT SPECIFICATION

DRAWINGS ATTACHED

1,025,165

1,025,165



Date of Application and filing Complete Specification: June 24, 1964.

No. 26204/64.

Application made in United States of America (No. 295,406) on July 16, 1963.

Complete Specification Published: April 6, 1966.

© Crown Copyright 1966.

Index at acceptance:—G3 TA5X

Int. Cl.:—G 04 c

COMPLETE SPECIFICATION

Improvements in or relating to Motion Transformers for Electronically Controlled Timepiece

We, BULOVA WATCH COMPANY, INC., a corporation organized under the laws of the State of New York, one of the United States of America, of 630 Fifth Avenue, City and State of New York, United States of America, do hereby declare the invention, for which we pray that a patent may be granted to us, and the method by which it is to be performed, to be particularly described in and by the following statement:—

This invention relates generally to electronically-controlled timepieces which incorporate electromagnetically-actuated tuning forks, and more particularly to improved motion transformers for converting the reciprocating movement of the tuning fork into rotary motion for driving the gear train of the timepiece.

In ordinary electric watches, make-and-break contacts are mechanically operated by the oscillation of the balance wheel. Each time these contacts close, battery current flows in a coil to electromagnetically impulse the balance wheel. Such mechanically operated make-and-break contact systems are subject to wear as well as to deterioration and contamination of the delicate contact points which must open and close an electric circuit without fail 216,000 times a day. The slightest sparking will cause rapid deterioration of these contacts and early failure of the watch.

Electronically controlled timepieces are now known which do away with a balance wheel and escapement, as well as with make-and-break contacts, see British Patent Specification 761,609. This timepiece employs a self-sufficient timekeeping standard formed by a tuning fork whose vibratory motion is sustained electromagnetically by a battery-energized transistor circuit. This motion is transmitted to a rotary movement including the usual gear train and dial pointers by means of an index finger attached to one tine of the

fork, the finger advancing a ratchet or index wheel which drives the gear train.

In British Patent Specification 955,559, there is disclosed a motion transformer for a timepiece, the transformer including a jewel-tipped index finger which engages the teeth of an index or ratchet wheel so that the oscillations of the tine transmit turning impulses to the wheel. Operating in conjunction with the index wheel is a pawl whose design is similar to that of the index finger, the pawl being pivotally attached to the pillar plate of the timepiece. The index finger and pawl are both tensioned downwardly such that when the finger is retracted by the tine, the resultant reverse torque produces a reverse rotation which is arrested by the pawl, the pawl being phased several teeth plus one-half tooth from the finger and being positioned in advance thereof, in the direction of wheel rotation.

One important problem which arises in a ratchet system of the type disclosed in the aforesaid British Patent Specification 955,559, is with respect to the phase relationship between the pawl and the index finger. While this relationship may be initially adjusted to a desired fixed value, it may be upset by the twisting of the pillar plate on which the pawl is mounted. Any deviation from this phase relationship lowers the strobe range and impairs the reliability and operation of the ratchet system. Twisting of the pillar plate frequently occurs when inserting and clamping the watch movement in a watch casing.

Accordingly, it is the principal object of this invention to provide a motion transformer in which the phase relationship between the ratchet wheel and the drive elements therefor is maintained constant, regardless of twisting of the pillar plate.

To this end, the invention consists in the provision of a timepiece comprising a tuning

45

50

55

60

65

70

75

80

85

[P...]

fork, means sustaining the fork in vibration at its natural frequency, and a motion transformer to convert the vibration of the fork into rotary motion for driving a gear train, the transformer including an index wheel for driving the train, an index finger mounted on one tine of the fork and engaging the wheel to rotate the same, and a pawl mounted on a stationary part of the fork and engaging the wheel to prevent reverse rotation thereof.

For a better understanding of the invention, reference is made to the following detailed description to be read in conjunction with the accompanying drawings wherein like components in the several figures are identified by like reference numerals.

In the drawings:

Fig. 1 is a schematic representation, in perspective, of the basic components of an electronic time piece including a motion transformer in accordance with the invention; and

Fig. 2 shows another preferred embodiment of a motion transformer in accordance with the invention;

Referring now to Fig. 1 of the drawings, the major components of a timepiece in accordance with the invention are a time-keeping standard constituted by a tuning fork 10 and an electronic drive circuit 11 therefor, a rotary movement of conventional design including a gear train 12 for turning the hands of the timepiece, and a motion transformer including an index wheel 13 operatively intercoupling the fork 10 and the rotary movement 12 and acting to convert the vibratory action of the fork into rotary motion.

All of the electrical components of the drive circuit are mounted on sub-assembly units or modules attached to a disc-shaped metallic pillar plate 14 which may be supported within a watch casing of standard design or within any other type of housing, depending on the use to which the timepiece is put.

Tuning fork 10 is provided with a pair of flexible tines 15 and 16 whose feet are interconnected by a relatively inflexible base 17, the base being provided with an upwardly extending stem 18 secured to the pillar plate by suitable screws 19 and 20. The central area of the pillar plate is cut out to permit unobstructed vibration of the tines.

The tuning fork is actuated by means of a first transducer  $T_1$  constituted by a magnetic element 21 secured to the free end of tine 15, the element coacting with a drive coil 22, and a phase sensing coil 23. Drive coil 22 is wound on an open-ended tubular carrier 24 affixed to a sub-assembly mounting form  $F_1$  which is secured to pillar plate 14. Coils 22 and 23 may be wound in juxtaposed relation on carrier 24 or the phase sensing coil 23 may be wound over drive coil 22.

A second transducer  $T_2$  is provided, con-

stituted by a magnetic element 25 secured to the free end of tine 16 and coacting with a drive coil 26 wound on a tubular carrier 27.

The electronic drive circuit 11 of the tuning fork comprises a transistor 28, a single-cell battery 29, and an R—C biasing network constituted by a condenser 30 shunted by a resistor 31. Transistor 28 is provided with base emitter and collector electrodes represented by letters B, E and C, respectively.

The base electrode is coupled through the R—C bias network 30—31 to one end of the phase-sensing coil 23, the other end of the coil being connected to one end of the drive coil section 22. The drive coil 26 is connected in a series with drive coil 22 to the collector electrode C of the transistor.

The emitter electrode E is connected to the positive terminal of the battery 29, the negative terminal thereof being connected to the junction of drive coil 22 and phase-sensing coil 23. Thus the battery is connected serially through both drive coils 22 and 26 between the emitter and collector electrodes of the transistor, the collector being negative relative to the emitter.

The transistor is preferably of the germanium junction type, and the polarity of the battery connection is shown as it exists when the transistor is of the PNP type. Obviously for other types of junction and point contact transistors made of such materials as silicon or germanium, the battery connections are arranged in accordance with the particular requirements.

The interaction of the electronic drive circuit and the tuning fork is self-regulating and functions not only to cause the tines to oscillate at their natural frequency, but also to maintain oscillation at a substantially constant amplitude. In practice, the amplitude of oscillation of the tines will be maintained at a substantially constant value or quickly returned to this value in the event of a mechanical disturbance. The electrical behavior of this circuit is set out more fully in the above-identified patent.

A tuning fork is a high "Q" mechanical oscillator and will vibrate at a natural frequency determined by the dimensions of the tines and the loading thereon which in this instance, is determined by the mass of magnetic elements attached to the free ends. The rate at which the timepiece movement is driven is directly proportional to the operating frequency of the vibrator, so that the accuracy of the timepiece may be regulated by predetermining the operative frequency of the tuning fork. In practice, a fork vibrating at 360 cycles per second may be used.

The vibratory motion of the tuning fork is converted by a motion transformer into rotary motion. This transformer is constituted by a ratchet and pawl mechanism

70

75

80

85

90

95

100

105

110

115

120

125

130

operated by the tuning fork to drive index wheel 13. The index wheel 13 acts as the actuator for the rotary movement 12 and it is therefore essential that this wheel be advanced by the vibratory fork at a constant rate. This is effected by means of an index finger 22 which is soldered or otherwise attached to a post 33 secured at one end to tine 16.

The index finger is in the form of a light leaf spring, and carries a tip which may be a precious or semi-precious stone, such as sapphire. The tip engages the teeth of index wheel 13 so that the oscillations of the tine transmit turning impulses to the wheel. The shaft of the wheel 13 is provided with a pinion which intermeshes with the first gear in the gear train 12.

Operating in conjunction with the index wheel 13 is a pawl 34 whose design is similar to that of the index finger, the pawl being attached to a post 35 mounted on a bracket 36 secured to stem 18 intermediate screws 19 and 20. The index finger and pawl are both tensioned downwardly, the jewelled tips thereof being parallel with the teeth of the index wheel. The tension is such that when the finger is retracted, there is sufficient reverse torque to cause the wheel to reverse direction. This backup, however, is arrested by pawl 34, which is phased several teeth plus one-half tooth from the finger and is positioned in advance thereof in the direction of wheel rotation.

The necessary phase adjustment between the finger and pawl can be effected by pivoting the ratchet wheel with its bearings around the center of the first gear train wheel, or by pivoting bracket plate 36, so that this adjustment can be made. In either case, the phase adjustment, once made, will be maintained, for the relationship is not distorted by twisting of the pillar plate, the pawl being independent of the pillar plate and being connected to a rigid portion of the fork.

In the modification shown in Fig. 2, a similar result may be accomplished by a fork

structure mounted on the pillar plate by a base extension 17a connected to the base 17 by a yieldable neck portion 17b, the fork being provided also with an upwardly extending, non-vibrating stem 18a. The stem 18a is inclined toward tine 16, and the pawl 34 is mounted thereon rather than on the pillar plate, thereby shortening the length of the pawl. Thus in the embodiments of Figs. 1 and 2, the pawl position relative to the index finger is not affected by twisting of the pillar plate, for the pawl and finger are both mounted on the fork.

#### WHAT WE CLAIM IS:—

1. A timepiece comprising a tuning fork, means sustaining the fork in vibration at its natural frequency, and a motion transformer to convert the vibration of the fork into rotary motion for driving a gear train, the transformer including an index wheel for driving the train, an index finger mounted on one tine of the fork and engaging the wheel to rotate the same, and a pawl mounted on a stationary part of the fork and engaging the wheel to prevent reverse rotation thereof.

2. A timepiece as claimed in claim 1, wherein the fork has a non-vibratory stem extending upwardly from the base of the fork between its tines, and the pawl is mounted on the stem.

3. A timepiece as claimed in claim 2, wherein the stem is inclined towards the one tine.

4. A timepiece as claimed in any one of the preceding claims, comprising a pillar plate, the gear train being mounted on the plate.

5. A timepiece having its parts constructed, arranged and adapted to operate substantially as hereinbefore described with reference to the accompanying drawings.

HASELTINE, LAKE & CO.,  
Chartered Patent Agents,  
28 Southampton Buildings,  
Chancery Lane,  
London, W.C.2.  
Agents for the Applicants.

This drawing is a reproduction of the Original on a reduced scale

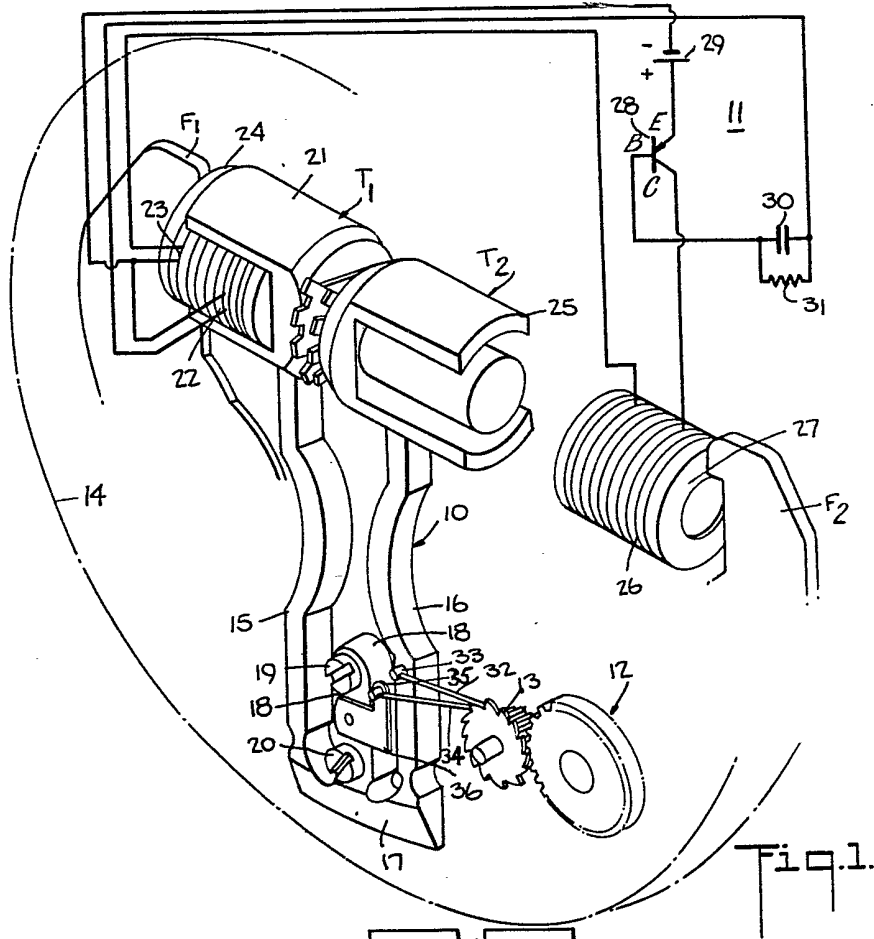

Fig. 1.

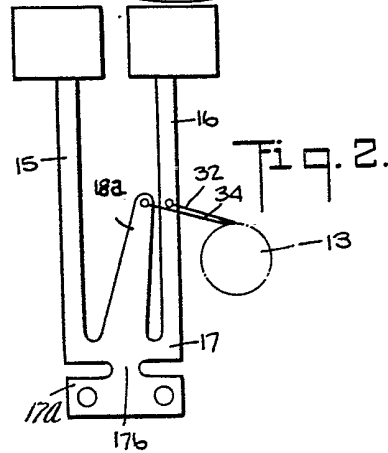

Fig. 2.